

CACTUS

Seat

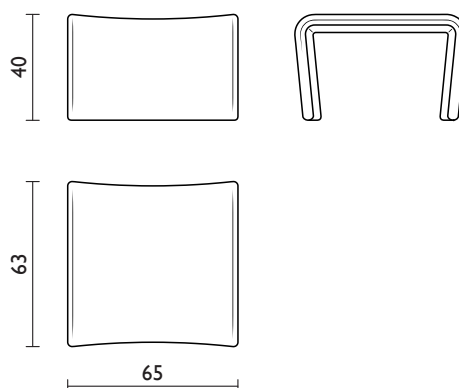

INFO AND MEASURES

Product code:	FA-CTS-001
Net weight:	10 kg
Required fabric:	140x140 cm

PADDING

Shell in flexible polyurethane made by casting in resin or aluminum molds.

- Density 60-70 kg/mc
- Fireproof material according to Italian class 1IM regulation
- Alternatively, California Technical Bulletin 117:2013 and English BS 5852-2-1982 on request

INTERNAL STRUCTURE

Shell: a metal frame with elastic bends is moulded in cold polyurethane foam.

PACKAGING

The product is packed in cardboard boxes

- Box measures: 78x60x55 cm
- Product net weight: 10 kg
- Box weight: 2 kg
- Pieces per box: 1
- Gross weight (products+box): 12 kg
- Boxes per pallet 80x120: 8 (2.3 m³)

BASES AND ACCESSORIES



FC-CTS-002



FC-CTS-003



FD-CTS-001



TINCTS06

CACTUS

Angular seat

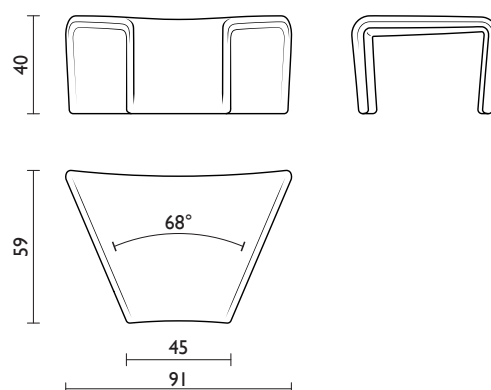

INFOS AND MEASURES

Product code:	FA-CTS-004
Net weight:	10.5 kg
Required fabric:	165x140 cm

PADDING

Shell in flexible polyurethane made by casting in resin or aluminum molds.

- Density 60-70 kg/mc
- Fireproof material according to Italian class 1IM regulation
- Alternatively, California Technical Bulletin 117:2013 and English BS 5852-2-1982 on request

INTERNAL STRUCTURE

Shell: a metal frame with elastic bends is moulded in cold polyurethane foam.

PACKAGING

The product is packed in cardboard boxes

- Box measures: 100x60x62 cm
- Product net weight: 10.5 kg
- Box weight: 3 kg
- Pieces per box: 1
- Gross weight (products+box): 13.5 kg
- Boxes per pallet 80x120: 8 (2.3 m³)

BASES AND ACCESSORIES



FC-CTS-002



FC-CTS-003



FD-CTS-001

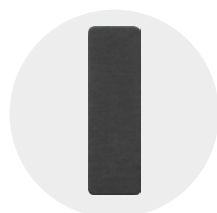

FD-CTS-004

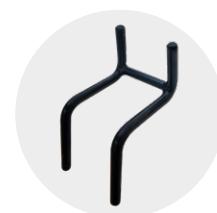

TINCTS06

CACTUS

High backrest (a) - low backrest (b)

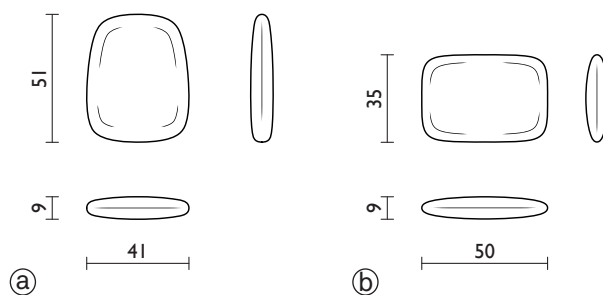

a: high backrest
b: low backrest

INFO AND MEASURES

Product code:	a: FC-CTS-002 b: FC-CTS-003
Net weight:	a: 1.8 kg b: 2 kg
Required fabric:	a: 50x140 cm b: 50x140 cm

PADDING

Backrests (a, b) in flexible polyurethane made by casting in resin or aluminum molds.

- Density 60-70 kg/mc
- Fireproof material according to Italian class 1IM regulation
- Alternatively, California Technical Bulletin 117:2013 and English BS 5852-2-1982 on request

INTERNAL STRUCTURE

Backrests (a, b) a metal frame is moulded in cold polyurethane foam.

PACKAGING

The product is packed with the seats.
For the dimensions, see the 'packaging' section of seats FA-CTS-001 and FA-CTS-004.

BASES AND ACCESSORIES



TINCTS06

CACTUS

Universal medium wall in wood and rubber (a)
Angular seat wall, tight side, in wood and rubber (b)

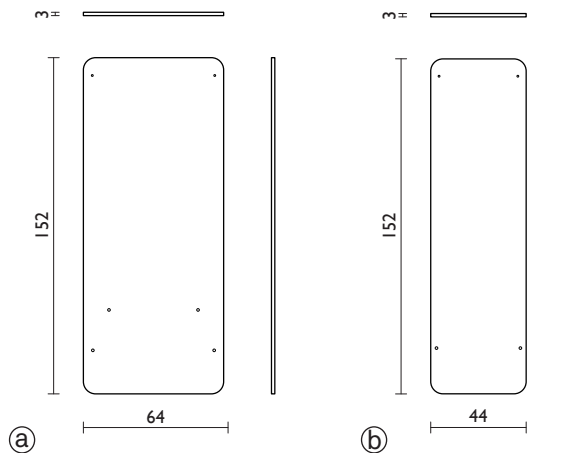

a: universal medium wall
b: tight wall

INFO AND MEASURES

Product code:	a: FD-CTS-001 b: FD-CTS-004
Net weight:	a: 9 kg b: 7 kg
Required fabric:	a: 200x140 cm b: 150x140 cm

ASSEMBLY

The walls are fixed to the seats with 2 M8 screws.
The universal wall can be fixed both to the seat and to the angular seat; the tight wall can only be fixed to the angular seat.

BASES AND ACCESSORIES



TINCTS180-NE



TINCTS90-NE



TINCTS156-NE



TINCTS114-NE

INTERNAL STRUCTURE AND PADDING

Wall (a, b): rubber sheets glued to the wood

PACKAGING

Products are shipped loose on pallets.