

DAKOTA

Armchair

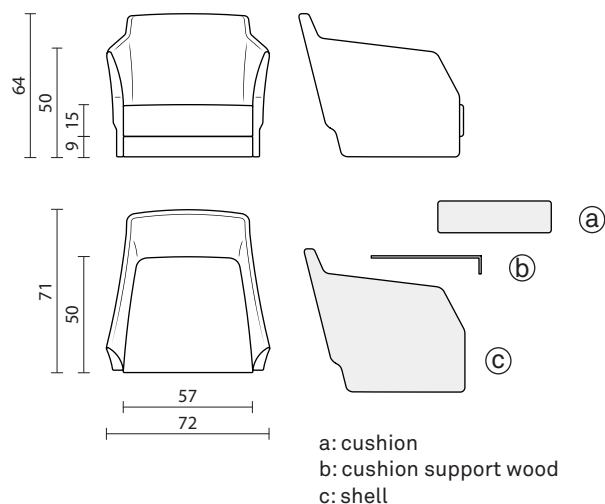

INFO AND MEASURES

Product code: FB-DKT-100
(a: FA-DKT-000)
(b: TF-DKT-000)
(c: FB-DKT-000)

Net weight: 11.5 kg

Required fabric: 380x140 cm

INTERNAL STRUCTURE

Shell (c): a metal frame is moulded in cold polyurethan foam.

The seat is made by a cushion (a) and a support in wood (b) with M6 T-nuts.

The padding has, where necessary, wooden or plastic stripes for stapling the fabric.

PADDING

Shell (c) in flexible polyurethane made by casting in resin or aluminum molds.

- Density 60-70 kg/mc
- Fireproof material according to Italian class 1IM regulation
- Alternatively, California Technical Bulletin 117:2013 and English BS 5852-2-1982 on request

Cushion (a) made from a rubber block.

PACKAGING

The product is packed in cardboard boxes

- Box measures: 73x66x81 cm
- Product net weight: 11.5 kg
- Box weight: 4 kg
- Pieces per box: 1
- Gross weight (products+box): 15.5 kg
- Boxes per pallet 80x120: 6 (2.5 m³)

BASES AND ACCESSORIES



SB-DKT-NE