

DOLAND

Armchair

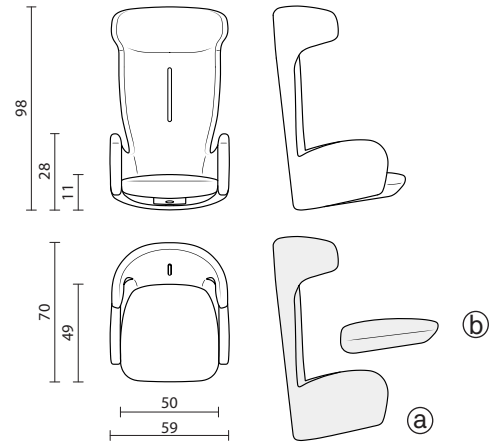

a: back
b: seat

INFO AND MEASURES

Product code:	FB-DLD-000 (a: FC-DLD-000) (b: FA-DLD-000)
Hole centres:	153x200 mm
Net weight:	14.5 kg
Required fabric:	270x140 cm

PADDING

Back (a) and seat (b) in flexible polyurethane made by casting in resin or aluminum molds.

- Density 60-70 kg/mc
- Fireproof material according to Italian class 1IM regulation
- Alternatively, California Technical Bulletin 117:2013 and English BS 5852-2-1982 on request

INTERNAL STRUCTURE

Back (a): a metal frame is moulded in cold polyurethane foam; the metal frame has a plate to fix the synchron mechanism. The seat (b) has a wood insert with M6 T-nuts to fix the synchron mechanism. The padding has, where necessary, wooden or plastic stripes for stapling the fabric.

PACKAGING

The product is packed in cardboard boxes

- Box measures: 70x65x100 cm
- Product net weight: 14.5 kg
- Box weight: 3 kg
- Pieces per box: 1
- Gross weight (products+box): 17.5 kg
- Boxes per pallet 80x120: 4 (2.1 m³)

BASES AND ACCESSORIES



SB-700-N18



SM3202015